

\_\_\_\_\_

-

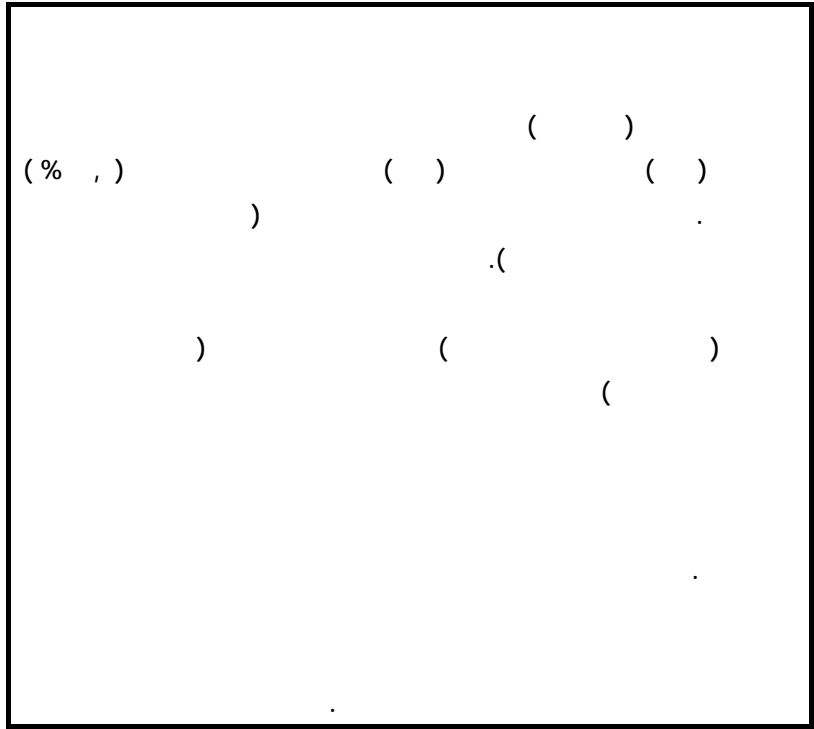

: -  
: -

**Career Development**

---

Edger Schein                      Peter Drucker

Career Pathing    Career Progression  
Career Development Services

Ottawa

. \*\* Oakland

: -

: -

- 
- Watts, A.G., "Career Development and policy ", Journal of Employment counseling, June .V. .
  - Splete, Howard; Hoppin, Judith M., "The Emergence of career Development Facilitators", Journal of Employment Counseling, June , V. .

---

:

.

-

.

-

.

-

.

-

:

-

:

( )

-

)

(

.

.

)

-

)

(

(

)

(

.

-

\_\_\_\_\_

..

: -

:

( )

.

( )

.

.

:

-

-

.

-

.

-

)

.(

:

-

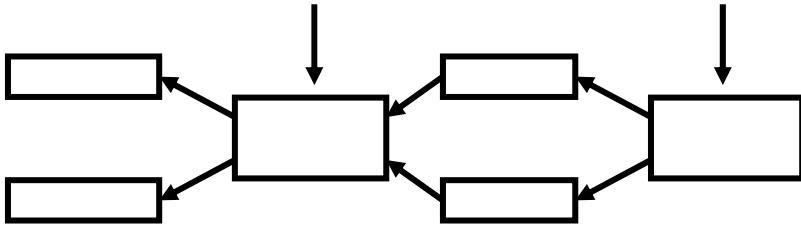

---

( )

:  
: **Functional Career** - -

.  
: **Functional Career Development** -

:

.( ) ( )  
: **Career planning** -

..  
: **Career Management** -

.  
: **Career Satisfaction** -

.  
:  
:  
-  
-

( ) ( )

- - -

)

(

%

( )

(% )

( )

(% )

( )

( )

:

( )

					**
%					
,					
,					
,					
%					

:

-

-

:

--

:

:

:

--

:

( )

(Kerry & Kris, ), (Ernst Karen, Sandra, ), (Christopher, )

( )

(\*\*)

( )

:

: ( )

( - ) - - - - -	:  :  -  -	-  -  -  -
( - ) ( ) ( ) ( )  ( ) ( ) ( )	:  :  -  -  -	-  -  -  -  -

:

-

:

( )

:

( )

---

- Orpen, Christopher, International Journal of Manpower, , V. , Issue .  
(\*\*)

- Bernes, Kerry & Magnusson, Kris, Journal of Counseling & Development, July/  
August , V. , Issue .

- Ernst, Karen, Sandra, Personnel Psychology, Winter , V. , Issue .



---

( )

( )

( )

“ ”

(Descriptive Statistic Measures)

(Pearson) (Simple Correlation)

:(Simple Regression)

(Univariate Analysis Variance)

:

:

:

---

Hall

( )

( )

-

( )

( )

( )

Beckhard

( )

Objective

Subjective

: Career Development

- -

" "

%

( )

Walter Storey

- -

( )

( )  
:Career Planning -

( ); Schein

( ) ; -

self-Assessment  
Career Planning Workshops

. Career workbooks - -

-

-

( )

( )

---

: Career Management -

job Rotation - -

Thomas Gutteridge

Norin & Kneisel .

self -

career satisfaction

Assessment

( ) .

:

( )

( )

( ) .

---

(\*)()

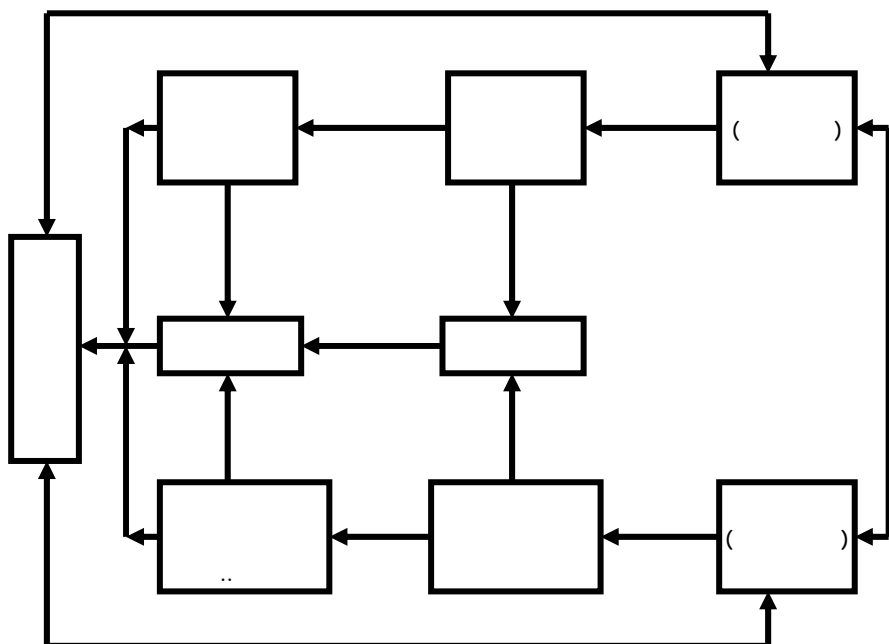

()

---

" ( )

(\*)

---

: Career Satisfaction

--

( ) ( )

( )

( )

( ),

:

--

( ) ( )

( )

**Recruitment , selection , appointment**

**Promotion          Transfer**

**Higher rank**

**Reassignment**

( )

( )

**selection**

( )

**compensation**

**Training and Development**

) ( )  
( ) ( )

**performance appraisal**

---

( )

**Orientation program**

( )

:

- -

**The Learning Organization**

( )

( )

( ):

-

-

-

-

( )

( )

:

-

:

.



- - -



( ) -

):

(

( )

( ) -

/

( )

( ) -

)

%

(

---

. ( )

: .

( Jennifer M, Chris) -

. ( )

( James J.) -

( )  
( $\chi$  T-test ANOVA)

. ( )

( Baruch ) -

( )

. ( )

( Louise ) -

( ) Quebec

( )

( Ellen Ernst ) -

( )

-

( )

( Rando ) -

)

(

( )

( Dianne ) -

- -

(CCI)

CCI

( )



( Kerry and Kris) -

Alberta

( )  
) ( ) ( ) ( )  
( ) ( )  
( ) ( )

Calgary

( )

( Marilyn & Elizabeth) -

( )

%

/

%

%

( )

( Stanley) -

( )

( )

( )

---

Posthoc

( )

( )

( Christopher ) -

Joint responsibility

( ) ( )

)

( , , , )

)

(

(

( )

( ) ( )

( Amy Elizabeth ) -

( )

-

( ) ( )

(

)

(

( )

( )

( Samuel ) -

( )

)

(



)

(

. ( )

( , Thomas N )

-

:

.

.

.

.

.

-

-

-

-

-

(

)

. ( )

( )

. . .

...

:

-

:

-

% ,

( )

(

)

. % ,

- ) % , ( ) % ,  
 .(% , ) ( )  
 (% , ) ( ) (% , )  
 (% , ) .(% , )  
 (% , ) .(% , % , )  
 (% , ) ( )  
 - ) ( - ) ( )  
 . (% , % , ) ( )

..

( )

% ,			
% ,			
% ,			
% ,		-	
% ,		-	
% ,			
% ,			
% ,			
% ,			
% ,			
% ,		/( )	
% ,			
% ,		-	

% ,		-	
% ,			

: ( ) -

( )

:( )

( )

					.
					.
					.
					.
					.
					.
					.
					.
					.
					.

: ( )

.( )  
( ) -  
( )





---

( )

( )

---

( )

( ) ( ) ( ) ( )

. ( )

( )

( ) ( ) ( ) ( ) ( )

( )

( )

.( ) ( ) ( ) -

) ( ) ( )  
( ) ( )

					) ( ( )
** /	** /	** /	** /	** /	
** /	** /	** /	** /	** /	
** /	** /	** /	** /	** /	

\*\* p < ,

) ( )  
: ( ) ( )  
)  
( ) ( ) ( , )  
( ) ( ) ( , ) ( )  
( )  
( , ) ( )  
( ) ( )  
( ) ( ) ( , )  
( ) ( ) ( )  
( )

					( )
** /	** /	** /	** /	/	**
** /	** /	** /	** /	/	**
** /	** /	** /	** /	/	

\_\_\_\_\_

				**	
--	--	--	--	----	--

\*\* p < ,

) ( )  
: ( ) ( )  
)  
( ) ( ) ( ) ( )  
( , ) ( ) ( ) ( , )  
( ) ( ) ( )  
( ) ( ) ( , )  
:  
( )  
( - )  
(p < , )  
( , ) ( )  
( , ) ( )  
( )  
( ) ( ) ( )  
( ) ( )  
( - <----> )  
( - <----> )

( - <----> )  
( - <----> )

( Christopher )

( Thomas N )

Louise )

(

(Jennifer M. Chris)

: -

( )  
( - ) ( )  
) ( )  
( ) ( )  
) :  
( ) ( )  
) ( )  
( ) ( )

<b>F</b>	<b>R</b>						( )
'	'	* ( ' )	( ' )	( ' )	* ( ' )	( ' )	
'	'	* ( ' )	( ' )	- ( ' )	( ' )	* ( ' )	
'	'			-			

		*(, )	(, )	(-. )	*(, )	*(, )	
--	--	-------	------	-------	-------	-------	--

\* p < ,

( )  
R ( )  
( ) ( ) ( , )  
( ) ( , ) ( , ) F  
) ( , )  
(t) Beta ( ) ( )  
( ) ( ) ( )  
( )  
. ( ) ( ) ( )  
( )  
R ( )  
) ( ) ( , )  
( , ) ( , ) F ( )  
.( , ) ( , )  
) ( )  
) (t) Beta ( )  
( ) ( ) ( ) ( )  
( ) ( )  
. ( )  
( , ) ( )  
( , ) F ( ) ( )  
.( , ) ( ) ( , )  
) (t) Beta ( )  
( ) ( ) ( ) ( )



( )

.( ) ( )

:

) ( ) .

( - ) (

) ( , , )

.( ) (

( ) ( ) .

( ) ( ) - -

( )

- - ( )

( ) ( )

.

) : :

(

) ( )

( ) (

<b>F</b>	<b>R</b>						) (
'	'	( ' ) *	( ' )	*( ' )	*( ' )	( ' )	
'	'	( ' ) *	( ' )	( ' )	*( ' )	( ' )	
'	'	( ' ) *	( ' )	( ' )	( ' )	( ' )	

\* P < ,

( ) ( )  
( , ) R ( )  
F ( ) ( )  
( ) ( , ) ( , )  
( , )  
( ) ( )  
) ( ) ( ) (t) Beta  
(  
( , ) ( )  
( ) ( , )  
( , ) ( , ) F  
( , ) ( )  
( ) ( )  
(t) Beta ( ) ( )  
( ) ( )  
)  
( , ) - - ( )  
( )  
( ) ( , ) F  
( )  
( , ) t ( , ) Beta  
)  
(

) ( )  
 ( - ) ( )  
 ) ( , , )  
 .( ) ( )  
 ) ( ) ( )  
 ) ( )  
 ( ) ( ) ( )  
 ) ( ) ( ) ( )  
 ( ) ( ) ( ) ( )  
 ( ) ( ) ( )

( ) (Christopher)

(Baruch)

( Thomas N)

(Stanley)

(Marilyn & Elizabeth)

) : :  
 )  
 .(

جدول رقم (١٢) نتائج تحليل التباين الثنائي لدرجة تأثير المتغيرات الشخصية في تصورات أفراد عينة البحث

	F				

) ( )  
 .(

( )

( )	( )	( )	
( ) *	( ) -	-	( )
( ) *	-	( )	( )
-	( ) -	( ) * -	( )

Scheffe

( )  
 .( ) ( )

(James. J)

Samuel

Rando

:

( )

( )

)

( )

(

( )

(T.test Beta )

( )

( )

)

) (

(

-

- -

---

)

(

:

:

-

( )

( )

:

-

-

-

\_\_\_\_\_

\_\_\_\_\_

) (

... ( ( :)

- 
- Orpen, Christopher, “ The effects of Organizational and Individual career Management on career success”, International Journal of Manpower, V. . , Issue , , [ephost@epnet.com](mailto:ephost@epnet.com).
  - McDougall, Marilyn, Vaughan, Elizabeth, “Changing expectations of career development, Implications for organizations and for Social Marketing”, Journal of Management Development, V. . , , [ephost@epnet.com](mailto:ephost@epnet.com).
  - Orpen, Christopher, Op.cit,([ephost@epnet.com](mailto:ephost@epnet.com)).
  - Olijnyk, zena, “win the loyalty game”, Canadian Business, V. . , Issue . , P. - .
  - Douglas T: Hall and Associates, “Career in Development”, Jossey- Bass Publishers, London, . , P. - .
  - Douglas T: Hall and Assoiates, Op.cit, P P. -
  - Bernardin, Russell , “ Human Resource Management, “ Irwin McGraw – Hill, . , PP. - .
  - Gary Dessler, “ Human Resource Management, “ Prentice- Hall, . , PP. - .
  - Bernardin, Russell, OP. Cit., P. .
  - Decenzo, Robbins, “Human Resource Management, “, John Wiley, Sons, . , PP.
  - Brown, Duane, “The role of Work and Cultural Values in occupational Choice, Satisfaction and Success: A theoretical Statement”, Journal of Counseling & Development, V. . , Issue . , Winter . , P. - .
  - Without Author, “Help Employees take charge of their Careers”, Work force, V. . , Issue . Jane, . , ([ephost@epnet.com](mailto:ephost@epnet.com)).
  - Daniels, Imogen; Schramm, Jennifer, “Evolution at Work”, People Management, V. . , Issuell, . , P. .
  - Dunlop, Robin, “Get the Skill- Set Rigth”, Management, V. . , Issue . , Mar . , P- .



---

-Jiang, James J., “ Supervisor Support and career Anchor impact on the career satisfaction of the Entry-Level information Systems Professional”, Journal of Management information Systems, V. , Issue , [ephost@epnet.com](mailto:ephost@epnet.com).

-Orpen Christopher, Op.cit, ([ephost@epnet.com](mailto:ephost@epnet.com)).

-Beryl Hesketh and Gillian cosidine, “Integration individual and organizational perspectives fo career Development and change”, European Journal of Work and organizational psychology, ( ), , P. .

-Douglas T: Hall and associates, Op.cit, P. .

-McDougall, Marilyn; Vaughan, Elizabeth, Op.cit, ([ephost@epnet.com](mailto:ephost@epnet.com)).

- Kaye, Beverly; Laibowitz, zandy, “Career Development”, HR Magazine, V. , Issue , Sep , ([ephost@epnet.com](mailto:ephost@epnet.com)).

- McDougall, Marilyn; Vaughan, Elizabeth, Op.cit,([ephost@epnet.com](mailto:ephost@epnet.com)).

- Bernardi, Russell, OP. Cit, P. .

- Collin, Audrey, “ New Challenges in the Study of Career”, Personnel Review, V. , Issue , ([ephost@epnet.com](mailto:ephost@epnet.com)).

- Decenzo, Robbins, OP. Cit. P. .

:

- 
- Kidd, Jennifer. M; Smewing, Chris, “ The role of the Supervisor in Career and organizational Commitment”, European Journal of Work and organizational psychology, V. , Issue ,Mar , ([ephost@epnet.com](mailto:ephost@epnet.com)).
  - Jiang, James j, Op.cit, ([ephost@epnet.com](mailto:ephost@epnet.com)).
  - Baruch, Y., “integrated career systems for the S, “ international journal of manpower, V. , Issue , , ([ephost@epnet.com](mailto:ephost@epnet.com)).
  - Lemire, Louise; Saba, Tania; Gagnon, Yves- Chantal, “Managing career plateauing in the Quebec Public Sector, “ Public Personnel Management”, V. , Issue , Fall , ([ephost@epnet.com](mailto:ephost@epnet.com)).
  - Elen Ernst, Karen, Sandra, “Career Self- management: A QUASI-Experimental Assessment of the effects of A Training intervention”, Personnel psychology, V. , Issue , Winter , ([ephost@epnet.com](mailto:ephost@epnet.com)).
  - Kim Rando, “Aspirations for career advancement in public organization: The case of South Korean bureaucracy”, Dissertation Abstracts international, V. , N. , Novem. , P. -A.
  - Edleman, Dianne, “The career challenge index”, Dissertation Abstracts international, V. , N. , April, , P. -A.
  - Bernes, Kerry; Magnusson, Kris, “A description of career development Services within Canadian organizations”, Journal of Counseling & Development, Jul/ Aug , V. , Issue , ([ephost@epnet.com](mailto:ephost@epnet.com)).
  - McDougall, Marilyn; Vaughan, Elizabeth, Op.cit, ([ephost@epnet.com](mailto:ephost@epnet.com)).
  - Bazan Stanley, “The effects of perceived Salience, and Clarity of the Self- concept on managerial career mobility”, Dissertation Abstracts international, V. , N. , April , P. -A.
  - Orpen, Christopher, Op.cit, ([ephost@epnet.com](mailto:ephost@epnet.com)).
  - Hurley, Amy Elizabeth, “A comparison of Actual Versus perceived determinates of career attainment”, Dissertation Abstracts international”, V. , N. , March , P. -A.
  - Aryee, Samuel; Debrah, Yaw A.; Yue Wash Chay, “An Investigation of ingratiation as a career management strategy: evidence from Singapore”, International journal of human Resource management, V. , Issue , Feb , ([ephost@epnet.com](mailto:ephost@epnet.com)).

---

- Garavan, Thomas N, "Promoting Strategic Career Development Activities: Some Irish Experience", *Industrial & commercial Training*, V. , Issue , , ([ephost@epnet.com](mailto:ephost@epnet.com)).

---

/

(x)

	( )	( )	:	-
-	( )	( )	:	-
	( )	- ( )		
	( )	( )	:	-
	( )	( )		
( )	/	/	( ) :	-
		( )		
-	( )	( )	:	-
	( )	- ( )		

:

:





---

( )	( )	( )	( )	( )		